

NAIL FIN INSTALLATION

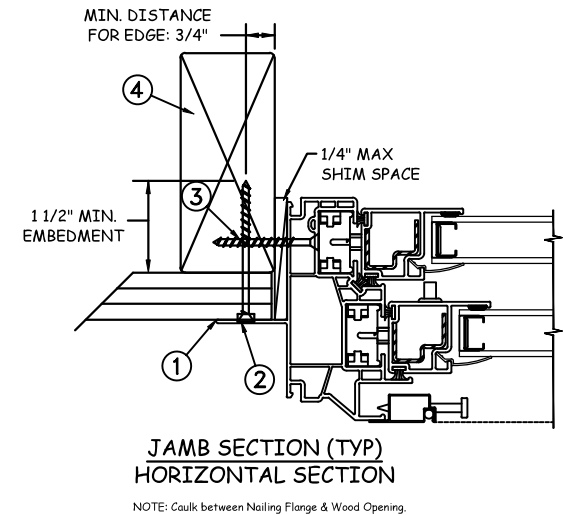

BUILDERS VINYL DOUBLE HUNG		
Max Frame	DP RATING	IMPACT
42 x 57	+/-50	NO

Installation Notes:

1. Seal flange/frame to substrate.
2. Use #8 X 1 1/4" PH or greater fastener through the nail fin with sufficient length to penetrate a minimum of 1" into the wood framing. For two (2X) wood frame substrate (min. S.G. = 0.42).
3. Use #8 X 1 1/4" PH or greater fastener through the frame at midspan with sufficient length to penetrate a minimum of 1" into the wood framing. For two (2X) wood frame substrate (min. S.G. = 0.42).
4. Host structure (wood buck, masonry, steel) to be designed and anchored to properly transfer all loads to the structure. The host structure is the responsibility of the architect or engineer of record for the project of installation.

This schedule addresses only the fasteners required to anchor the window to achieve the rated design pressure up to the size limitations noted. It is not intended as a guide to the installation process and does not address the sealing consideration that may arise in different wall conditions. For the complete installation procedure, see the instructions packaged with the window or go to www.jeld-wen.com/resources/installation.

DISCLAIMER:

This drawing and its contents are confidential and are not to be reproduced or copied in whole or in part or used or disclosed to others except as authorized by JELD-WEN Inc.

General Notes:

1. The product shown herein is designed, tested and manufactured to comply with the wind load criteria of the adopted International Building Code (IBC), the International Residential Code (IRC), the Florida Building Code (FBC) and the industry requirements for the stated conditions.
2. All glazing shall conform to ASTM E1300.
3. At minimum, glazing shall be 3/32" annealed - 3/32" annealed insulating glass.
4. Use structural or composite shims where required.

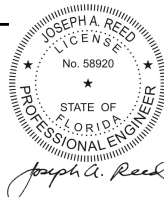

2021.02.03 08:15:29 -05'00'

JOSEPH A. REED, P.E.
Florida PE 58920, REG. No. 33474
National Certified Testing Laboratories
5 Leigh Drive, York, PA. 17406
(717) 846-1200

PROJECT ENGINEER: --	DATE: 09/16/2014
DRAWN BY: D. Vezo	SCALE: NTS
CHECKED BY: J. Kantola	TITLE:
APPROVED BY: --	
PART/PROJECT No.:	
D008303	
IDENTIFIER No.:	PLANT NAME AND LOCATION:
SJW2012-173/253-FBC	

JELD-WEN 3737 Lakeport Blvd
Klamath Falls, OR, 97601
Phone: (800) 535-3936

Builders Vinyl Double Hung Window
Nail Fin Installation (42" x 57")

CAD DWG. No.:	REV: 00	SHEET 1 OF 4
---------------	---------	--------------

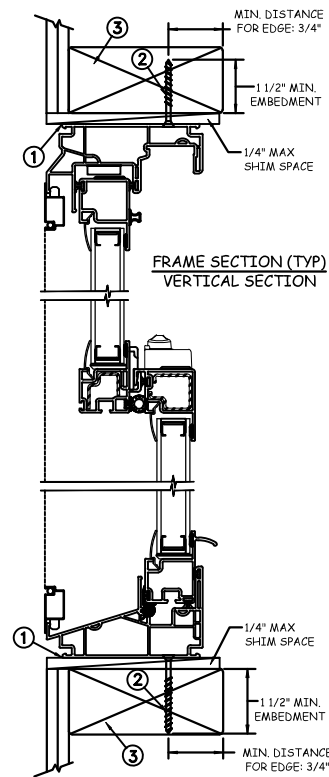
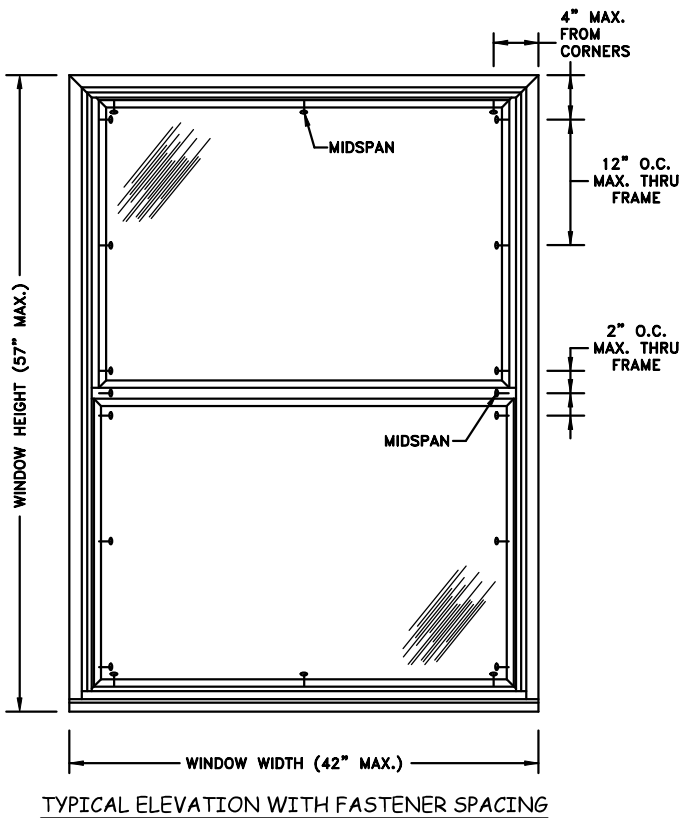

THROUGH FRAME INSTALLATION

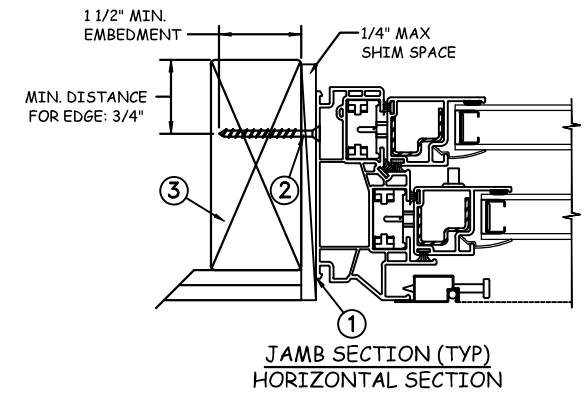

BUILDERS VINYL DOUBLE HUNG		
Max Frame	DP RATING	IMPACT
42 x 57	+/-50	NO

Installation Notes:

1. Seal flange/frame to substrate.
2. Use #8 PH or greater fastener through the frame per location with sufficient length to penetrate a minimum of 1 1/2" into the wood framing. For 2x wood frame substrate (min. S.G. = 0.42).
3. Host structure (wood buck, masonry, steel) to be designed and anchored to properly transfer all loads to the structure. The host structure is the responsibility of the architect or engineer of record for the project of installation.

General Notes:

1. The product shown herein is designed, tested and manufactured to comply with the wind load criteria of the adopted International Building Code (IBC), the International Residential Code (IRC), the Florida Building Code (FBC) and the industry requirements for the stated conditions.
2. All glazing shall conform to ASTM E1300.
3. At minimum, glazing shall be 3/32" annealed - 3/32" annealed insulating glass.
4. Use structural or composite shims where required.

This schedule addresses only the fasteners required to anchor the window to achieve the rated design pressure up to the size limitations noted. It is not intended as a guide to the installation process and does not address the sealing consideration that may arise in different wall conditions. For the complete installation procedure, see the instructions packaged with the window or go to www.jeld-wen.com/resources/installation.

DISCLAIMER:

This drawing and its contents are confidential and are not to be reproduced or copied in whole or in part or used or disclosed to others except as authorized by JELD-WEN Inc.

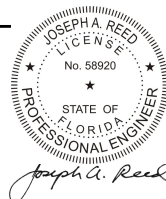

2021.02.03 08:15:29 -05'00'

JOSEPH A. REED, P.E.
 Florida PE 58920, REG. No. 33474
 National Certified Testing Laboratories
 5 Leigh Drive, York, PA. 17406
 (717) 846-1200

PROJECT ENGINEER: --	DATE: 09/16/2014
DRAWN BY: D. Vezo	SCALE: NTS
CHECKED BY: J. Kantola	TITLE:
APPROVED BY: --	
PART/PROJECT No.: D008303	
IDENTIFIER No. SJW2012-173/25	PLANT NAME AND LOCATION: 3-FBC

JELD-WEN 3737 Lakeport Blvd
 Klamath Falls, OR, 97601
 Phone: (800) 535-3936

Builders Vinyl Double Hung Window
 Through Frame Installation (42" x 57")

CAD DWG. No.:	REV: 00	SHEET 2 OF 4
---------------	---------	--------------

MASONRY INSTALLATION

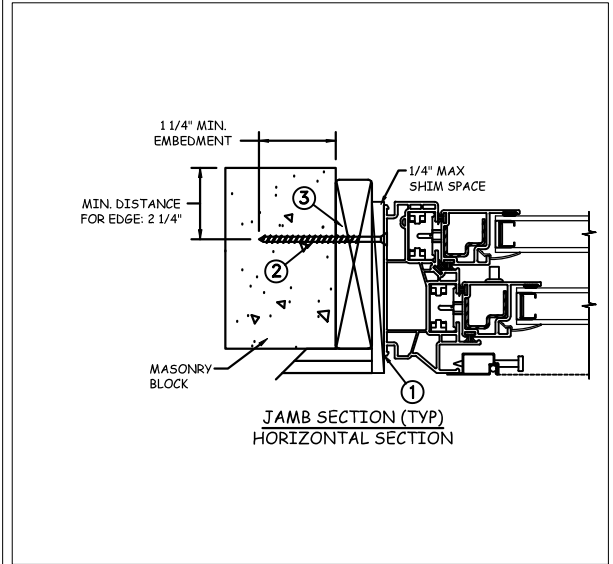
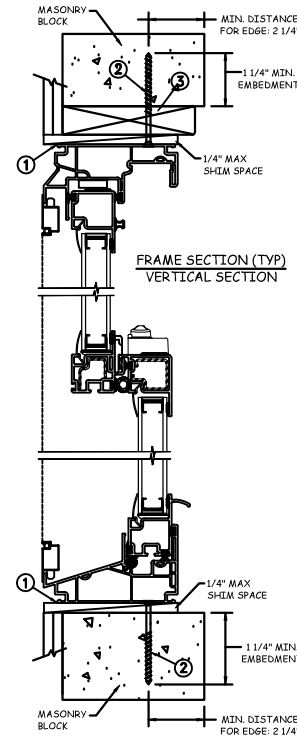
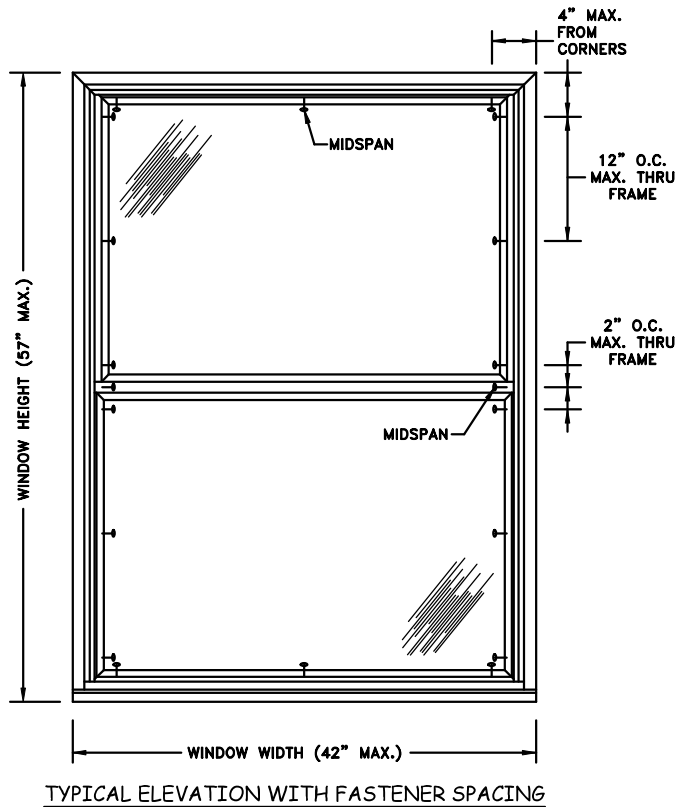

BUILDERS VINYL DOUBLE HUNG		
Max Frame	DP RATING	IMPACT
42 x 57	+/-50	NO

Installation Notes:

1. Seal flange/frame to substrate.
2. Use 3/16" Tapcon or fastener of equivalent capacity through frame per location with sufficient length to penetrate a minimum of 1 1/4" into concrete or masonry at each location with a 2 1/4" min. distance from the edge. For concrete (min. fc = 3000 psi) or masonry substrate (CMU shall conform to ASTM C90).
3. Host structure (wood buck, masonry, steel) to be designed and anchored to properly transfer all loads to the structure. The host structure is the responsibility of the architect or engineer of record for the project of installation.

General Notes:

1. The product shown herein is designed, tested and manufactured to comply with the wind load criteria of the adopted International Building Code (IBC), the International Residential Code (IRC), the Florida Building Code (FBC) and the industry requirements for the stated conditions.
2. All glazing shall conform to ASTM E1300.
3. At minimum, glazing shall be 3/32" annealed - 3/32" annealed insulating glass.
4. Use structural or composite shims where required.

This schedule addresses only the fasteners required to anchor the window to achieve the rated design pressure up to the size limitations noted. It is not intended as a guide to the installation process and does not address the sealing consideration that may arise in different wall conditions. For the complete installation procedure, see the instructions packaged with the window or go to www.jeld-wen.com/resources/installation.

DISCLAIMER:

This drawing and its contents are confidential and are not to be reproduced or copied in whole or in part or used or disclosed to others except as authorized by JELD-WEN Inc.

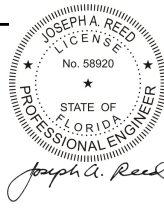

2021.02.03 08:15:29 -05'00'

JOSEPH A. REED, P.E.
 Florida PE 58920, REG. No. 33474
 National Certified Testing Laboratories
 5 Leigh Drive, York, PA. 17406
 (717) 846-1200

PROJECT ENGINEER: --	DATE: 09/16/2014
DRAWN BY: D. Vezo	SCALE: NTS
CHECKED BY: J. Kantola	TITLE:
APPROVED BY: --	
PART/PROJECT No.:	
IDENTIFIER No.:	
PLANT NAME AND LOCATION:	
SJW2012-173/253-FBC	

JELD-WEN 3737 Lakeport Blvd
 Klamath Falls, OR, 97601
 Phone: (800) 535-3936

Builders Vinyl Double Hung Window
 Masonry Installation (42" x 57")

CAD DWG. No.:	REV: 00	SHEET 3 OF 4
---------------	---------	--------------

STEEL INSTALLATION

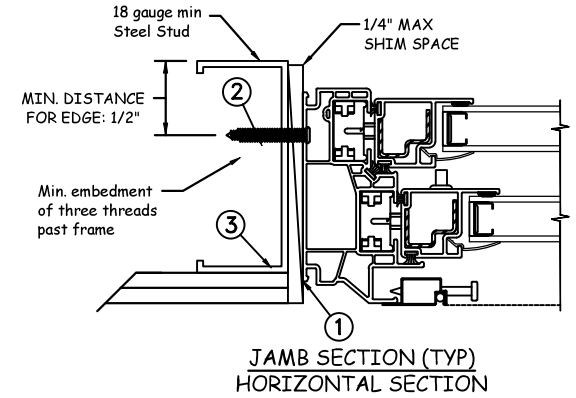
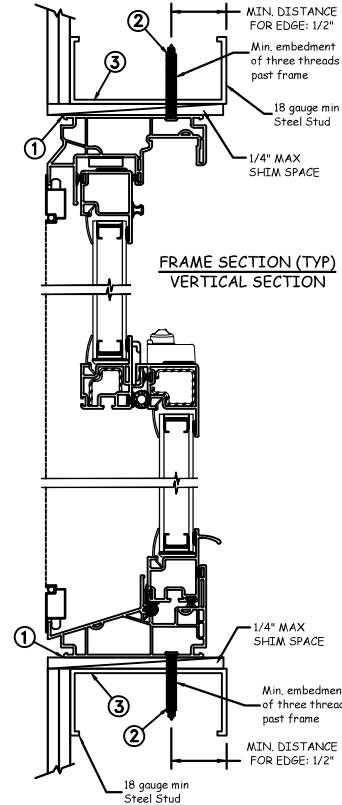
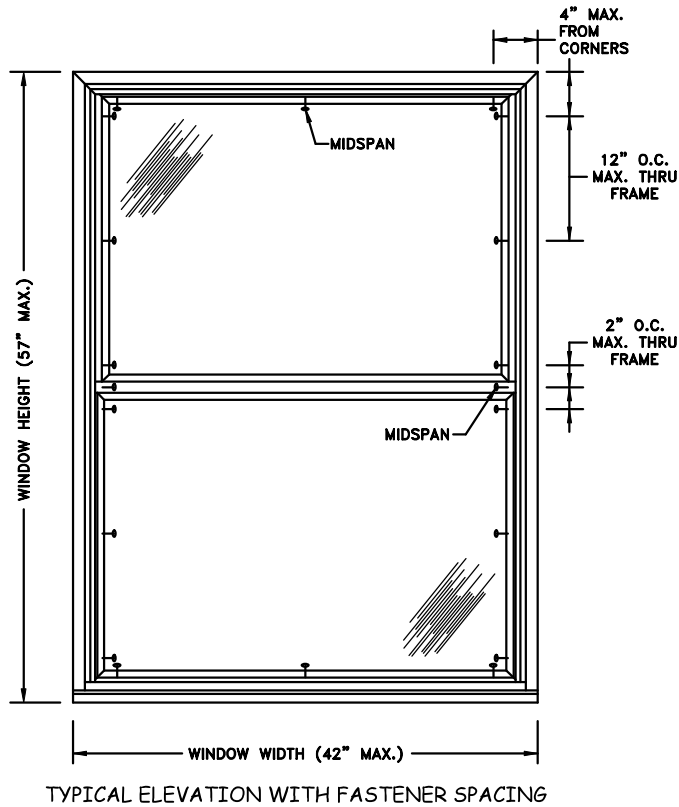

BUILDERS VINYL DOUBLE HUNG		
Max Frame	DP RATING	IMPACT
42 x 57	+/-50	NO

Installation Notes:

1. Seal flange/frame to substrate.
2. For anchoring into metal framing, use #8 TEK Self Tapping screws per location with sufficient length to achieve a minimum embedment of three threads past the frame thickness. Locate anchors as shown in elevations and installation details. Steel substrate min. 18 ga (fy = 33 ksi).
3. Host structure (wood buck, masonry, steel) to be designed and anchored to properly transfer all loads to the structure. The host structure is the responsibility of the architect or engineer of record for the project of installation.

General Notes:

1. The product shown herein is designed, tested and manufactured to comply with the wind load criteria of the adopted International Building Code (IBC), the International Residential Code (IRC), the Florida Building Code (FBC) and the industry requirements for the stated conditions.
2. All glazing shall conform to ASTM E1300.
3. At minimum, glazing shall be 3/32" annealed - 3/32" annealed insulating glass.
4. Use structural or composite shims where required.

This schedule addresses only the fasteners required to anchor the window to achieve the rated design pressure up to the size limitations noted. It is not intended as a guide to the installation process and does not address the sealing consideration that may arise in different wall conditions. For the complete installation procedure, see the instructions packaged with the window or go to www.jeld-wen.com/resources/installation.

DISCLAIMER:

This drawing and its contents are confidential and are not to be reproduced or copied in whole or in part or used or disclosed to others except as authorized by JELD-WEN Inc.

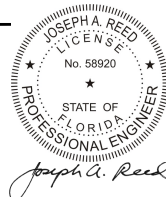

2021.02.03 08:15:29 -05'00'

JOSEPH A. REED, P.E.
 Florida PE 58920, REG. No. 33474
 National Certified Testing Laboratories
 5 Leigh Drive, York, PA. 17406
 (717) 846-1200

PROJECT ENGINEER: --	DATE: 09/16/2014
DRAWN BY: D. Vezo	SCALE: NTS
CHECKED BY: J. Kantola	TITLE:
APPROVED BY: --	
PART/PROJECT No.:	
D008303	
IDENTIFIER No.:	PLANT NAME AND LOCATION:
SJW2012-173/253-FBC	

JELD-WEN 3737 Lakeport Blvd
 Klamath Falls, OR, 97601
 Phone: (800) 535-3936

Builders Vinyl Double Hung Window
 Steel Installation (42" x 57")

CAD DWG. No.:	REV: 00	SHEET 4 OF 4
---------------	---------	--------------